

100 Glycan Array User Manual

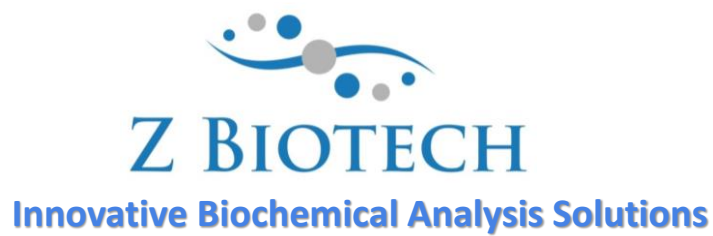

Website: <http://www.zbiotech.com/home.html>

Tel: (720) 285-3587

Email: info@zbiotech.com

For Research Use Only

Copyright 2022, Z Biotech, LLC. All Rights Reserved.

Introduction

Glycans attached to cell membranes and other types of proteins are the primary determinants for binding activity and consecutive cellular function. The study of the function and characteristics of these sugars is a fundamental part of immunology research and is applicable in understanding a variety of intercellular interactions. New technologies such as microarray for glycan-binding applications allow researchers to investigate and reveal new information about this wide and developing field of glycoscience.

Z Biotech's 100 Glycan Array is used as a general test to help researchers determine binding characteristics of antibodies, proteins, bacteria, cell cultures, or other potential biological samples to an array of 100 glycans representing the range of glycans found glycosylated to cell membranes. Our microarray slides are especially coated to be capable of immobilizing natural glycans with close-ring structure at their free-reducing end.

This manual is provided as a comprehensive guide to help the researcher acquire clear results from the assay. Please read through carefully before starting your experiment.

Handling and Storage

Store the bag of slides and any buffers in a 4°C refrigerator if they are to be assayed within 24 hours upon receipt. For long term storage keep the bag of slides at -20°C. Avoid freezing and thawing multiple times. Purchased slides and buffers should be used within 6 months.

Allow the bag of slides to equilibrate to room temperature at least 20 minutes before opening. After opening, re-seal any unused slides in the moisture barrier bag with a desiccant inside and refreeze. Handle the slides in a clean, dust free environment. Wear gloves and hold the slides on the edges. When adding sample do not touch the pipette tip to the array surface. When removing sample gently touch the pipette tip at the corner of the well of the cassette and tip the slide so that the sample pools to that corner. Avoid contact with the surface of the slides.

Array Map/Schematic

100 Glycan Array slides have 8 or 16 subarrays depending on the customer's request. Arrays are printed on the side with the "Z Biotech" label and 4-digit number ID facing upward. The "Z Biotech" label is located on the bottom center from a landscape view. The number ID is consistent with the barcode ID on the bottom from a portrait view. Dimensions and array maps are shown below.

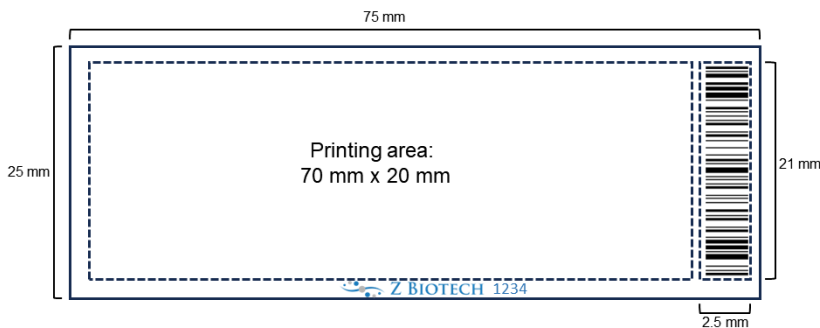

100 Glycan Identification List:

No.	Glycan Structure	Name
1	D-Mannose	D-Mannose
2	D-Glucose	D-Glucose
3	D-Fucose	D-Fucose
4	D-Galactose	D-Galactose
5	L-Fucose	L-Fucose
6	L-Rhamnose	L-Rhamnose
7	D-ManNAc	D-ManNAc
8	D-GlcNAc	D-GlcNAc
9	Neu5Ac	Sialic acid
10	Gal β 1-4(Fuca α 1-3)Glc	3FL
11	Gal β 1-4Glc	Lactose
12	Gal β 1-4GlcNAc	LacNAc
13	Gal β 1-3GlcNAc	Lac-N-biose
14	Gal β 1-4Gal	4- β -Galactobiose
15	GalNAc β 1-3Gal	β -D-N-acetyl-galactosaminyl 1-3 galactose
16	Glc α 1-4Glc	Maltose
17	Glc β 1-4Glc	Cellulose
18	GlcNAc β 1-4GlcNAc	Diacetylchitobiose
19	GlcNAc β 1-2Man	β -D-N-acetylglucosaminyl 1-2 mannose
20	GlcNAc β 1-4MurNAc	GlcNAcMurNAc
21	GlcNH $_2$ β 1-4GlcNH $_2$	Chitobiose
22	Man α 1-2Man	2-Mannobiose
23	Man α 1-3Man	3-Mannobiose
24	Man α 1-4Man	4-Mannobiose
25	Man α 1-6Man	6-Mannobiose
26	Fuca α 1-2Gal	Blood H Disaccharide
27	Δ GlcA(2S) α 1-4GlcNS(6S)	Heparin Disaccharide
28	GlcNH $_2$ β 1-4GlcNH $_2$ β 1-4GlcNH $_2$	Chitotriose
29	Gal β 1-4Gal β 1-4Glc	Globotriose (P ^K antigen)
30	GlcNAc β 1-4GlcNAc β 1-4GlcNAc	Triacetyl chitotriose
31	Neu5Ac α 2-3Gal β 1-4Glc	3'-SL (GM3 Glycan)
32	Neu5Ac α 2-6Gal β 1-4Glc	6'-SL
33	Neu5Ac α 2-3Gal β 1-4GlcNAc	3'-SLN
34	Neu5Ac α 2-6Gal β 1-4GlcNAc	6'-SLN
35	SO $_3$ -3Gal β 1-4(Fuca α 1-3)GlcNAc	Sulpho-Lewis x
36	SO $_3$ -3Gal β 1-3(Fuca α 1-4)GlcNAc	Sulpho-Lewis a
37	Gal β 1-4(Fuca α 1-3)GlcNAc	Lewis x Trisaccharide
38	Gal β 1-3(Fuca α 1-4)GlcNAc	Lewis a Trisaccharide
39	Glc α 1-4Glc α 1-4Glc	Maltotriose
40	Glc β 1-4Glc β 1-4Glc	Cellotriose
41	Fuca α 1-2Gal β 1-4Glc	2'FL
42	Gal β 1-3Gal β 1-3GlcNAc	Linear B-2 Tri (Blood Group B Type 2 Linear Tri)
43	Gal α 1-4Gal β 1-4GlcNAc	P1 antigen Tri
44	Fuca α 1-2Gal β 1-3GlcNAc	Blood group H Trisaccharide
45	GalNAc α 1-3-(Fuca α 1-2)Gal	Blood group A Trisaccharide
46	Gal α 1-3(Fuca α 1-2)Gal	Blood group B Trisaccharide
47	Gal β 1-3GlcNAc β 1-3Gal β 1-4Glc	Lacto-N-tetraose (LNT)
48	Gal β 1-4GlcNAc β 1-3Gal β 1-4Glc	Lacto-N-neotetraose (LNnT)
49	Gal α 1-3Gal β 1-4Gal β 1-3Gal	Gal4
50	Glc α 1-4Glc α 1-4Glc α 1-4Glc	Maltotetraose

No.	Glycan Structure	Name
51	Neu5Ac α 2-3Gal β 1-4(Fuca1-3)GlcNAc	Sialyl Lewis x
52	Neu5Ac α 2-3Gal β 1-3(Fuca1-4)-GlcNAc	Sialyl Lewis a
53	Fuca1-2Gal β 1-3(Fuca1-4)GlcNAc	Lewis b Tetrasaccharide
54	Fuca1-2Gal β 1-4(Fuca1-3)GlcNAc	Lewis y Tetrasaccharide
55	Fuca1-2Gal β 1-3GlcNAc β 1-3Gal β 1-4Glc	Lacto-N-Fucopentaose I (LNFP-I)
56	Gal β 1-3(Fuca1-4)GlcNAc β 1-3Gal β 1-4Glc	Lacto-N-Fucopentaose II (LNFP-II)
57	Gal β 1-4(Fuca1-3)GlcNAc β 1-3Gal β 1-4Glc	Lacto-N-Fucopentaose III (LNFP-III)
58	Fuca1-2Gal β 1-4(Fuca1-3)GlcNAc β 1-3Gal	Lewis y Pentasaccharide
59	Glc α 1-4Glc α 1-4Glc α 1-4Glc α 1-4Glc	Maltopentaose
60	[Man α 1-3-(Man α 1-6)-Man α 1-6]- (Man α 1-3)-Man	Man5
61	Neu5Ac α 2-6(Gal β 1-3)GlcNAc β 1-3Gal β 1-4Glc	LS-Tetrasaccharide b (LsTb)
62	Neu5Ac α 2-6Gal β 1-4GlcNAc β 1-3Gal β 1-4Glc	LS-Tetrasaccharide c (LsTc)
63	Gal β 1-3GalNAc β 1-4(Neu5Ac α 2-3)Gal β 1-4Glc	GM1 Glycan
64	GalNAc α 1-3(Fuca1-2)Gal β 1-4(Fuca1-3)Glc	Blood Group A Pentasaccharide
65	(GlcNAc β 1-2Man α 1) ₂ -1-3,6Man	Biantennary N-linked Core Pentasaccharide
66	Gal β 1-3(Fuca1-4)GlcNAc β 1-3Gal β 1-4(Fuca1-3)Glc	Lacto-N-difucohexaose II (LNDFH II)
67	Neu5Ac α 2-3Gal β 1-3(Neu5Ac α 2-6)GlcNAc β 1-3Gal β 1-4Glc	DSLNT
68	GlcNAc β 1-4GlcNAc β 1-4GlcNAc β 1-4GlcNAc β 1-4GlcNAc β 1-4GlcNAc	Hexaacetyl Chitohexaose
69	Glc α 1-4Glc α 1-4Glc α 1-4Glc α 1-4Glc α 1-4Glc	Maltohexaose
70	Glc α 1-4Glc α 1-4Glc α 1-4Glc α 1-4Glc α 1-4Glc α 1-4Glc	Maltoheptaose
71	(4GlcA β 1-4GlcNAc(6S) α 1) ₄	Heparin Octasaccharide
72	Man α 1-6(Man α 1-3)Man α 1-6(Man α 1-3)Man β 1-4GlcNAc β 1-4GlcNAc	MAN-5; (Man)5(GlcNAc)2
73	Man α 1-2Man α 1-6(Man α 1-2Man α 1-3)Man α 1-6(Man α 1-2Man α 1-2Man α 1-3)Man β 1-4GlcNAc β 1-4GlcNAc	MAN-9; (Man)9(GlcNAc)2
74	GalNAc α 1-3(Fuca1-2)Gal β 1-3GlcNAc	Blood Group A Type 1 Tetrasaccharide
75	GalNAc α 1-3(Fuca1-2)Gal β 1-4GlcNAc	Blood Group A Type 2 Tetrasaccharide
76	GalNAc α 1-3(Fuca1-2)Gal β 1-3GalNAc	Blood Group A Type 3/4 Tetrasaccharide
77	Gal α 1-3-(Fuc1-2)Gal β 1-4(Fuca1-3)Glc	Blood Group B Pentasaccharide
78	Gal α 1-3-(Fuc1-2)Gal β 1-3GlcNAc	Blood Group B Type 1 Tetrasaccharide
79	Gal α 1-3-(Fuc1-2)Gal β 1-4GlcNAc	Blood Group B Type 2 Tetrasaccharide
80	Gal α 1-3-(Fuc1-2)Gal β 1-3GalNAc	Blood Group B Type 3/4 Tetrasaccharide
81	Neu5Ac α 2-3Gal β 1-4(Fuca1-3)GlcNAc β 1-3Gal	Sialyl Lewis x Pentasaccharide
82	Neu5Ac α 2-3(GalNAc β 1-4)Gal β 1-4Glc	GM2 Glycan
83	Neu5Ac α 2-3Gal β 1-3GlcNAc β 1-3Gal β 1-4Glc	LS-Tetrasaccharide a (LsTa)
84	Neu5Ac α 2-3Gal β 1-4GlcNAc β 1-3Gal β 1-4Glc	LS-Tetrasaccharide d (LsTd)
85	Neu5Ac α 2-3Gal β 1-3GalNAc β 1-3Gal	Stage-specific Embryonic Antigen 4 (SSEA-4)
86	Glc β 1-4Glc β 1-4Glc β 1-4Glc	Cellotetraose
87	Glc β 1-4Glc β 1-4Glc β 1-4Glc β 1-4Glc	Cellopentaose
88	Glc β 1-4Glc β 1-4Glc β 1-4Glc β 1-4Glc β 1-4Glc	Cellohexaose
89	D-GalNAc	D-GalNAc
90	Gal β 1-3GalNAc	T antigen
91	GalNAc α 1-3Gal	Adi
92	GalNAc α 1-3Gal β 1-4Glc	α -D-N-Acetylgalactosaminyl 1-3 galactose β 1-4 glucose
93	Gal β 1-6Gal	β 1-6 galactobiose
94	GalNAc α 1-3GalNAc	Forsman disaccharide
95	GalNAc β 1-4Gal	Receptor for pili of Pseudomonas aeruginosa
96	Gal β 1-3GalNAc β 1-3Gal α 1-4Gal β 1-4Glc	Stage-specific Embryonic Antigen 3 (SSEA-3)
97	Fuca1-2Gal β 1-3GalNAc β 1-3Gal α 1-4Gal β 1-4Glc	Globo-H
98	Man α 1-6(Man α 1-3)Man α 1-6(Man α 1-2Man α 1-3)Man β 1-4GlcNAc β 1-4GlcNAc	MAN-6; (Man)6(GlcNAc)2
99	[Man α 1-2]Man α 1-6(Man α 1-3)Man α 1-6(Man α 1-2Man α 1-3)Man β 1-4GlcNAc β 1-4GlcNAc (3 isomers)	MAN-7; (Man)7(GlcNAc)2
100	[Man α 1-2] [Man α 1-2] Man α 1-6(Man α 1-3)Man α 1-6(Man α 1-2Man α 1-3)Man β 1-4GlcNAc β 1-4GlcNAc (3 isomers)	MAN-8; (Man)8(GlcNAc)2

Controls

NC: Negative control, Print Buffer

PC1: Positive control 1, Biotinylated Mannose (0.01 mg/mL)

PC2: Positive control 2, Human IgG (0.1 mg/mL)

PC3: Positive control 3, Mouse IgG (0.1 mg/mL)

PC4: Positive control 4, Rabbit IgG (0.1 mg/mL)

Marker: Anti-human IgG, Cy3 (0.01 mg/mL) and anti-Human IgG, Alexa647 (0.01 mg/mL)

Materials Required

- Arrayed glass slides
- 16 or 8 cassettes
- Glycan Array Blocking Buffer (GABB, Item #10106), add 1% BSA (10 mg/ml) if needed
- Glycan Array Assay Buffer (GAAB, Item #10107), add 1% BSA (10 mg/ml) if needed
- Laser fluorescence scanner (able to scan at the wavelength of your fluorophore)
- Coplin jar
- Adhesive slide cover film

Preparation of assay samples:

Prepare glycan-binding protein samples or secondary antibodies of interest in a centrifuge tube by diluting with the Glycan Array Assay Buffer. We recommend a range of 50 µg/ml to 0.1 µg/ml concentration for protein samples, although some experimentation may be required to establish the concentration that will provide the highest binding signals with the lowest background fluorescence. This is often accomplished by applying a different dilution of samples to different wells of the array. For the fluorescently labelled streptavidin we recommend a concentration of 1 µg/mL. Calculate the volume of sample needed depending on how many slides and subarrays are to be assayed. **We recommend using 100 µL volume of sample per well for 16 subarray cassettes and 200 µL for 8 subarray cassettes to ensure full and even coverage of the printed area throughout incubation for every step of the assay.** If necessary, the assay can be done successfully with a minimal volume of 60 µL per well for 16 subarray cassettes and 80 µL for 8 subarray cassettes. We caution that using a minimal volume in the wells has an increased risk of the array drying out during the assay and may also cause unequal distribution of the sample across the arrayed surface which may result in signal variation. Please ensure each sample is homogeneous and thoroughly mixed.

Assay Protocol

Part 1 – Blocking

Handle the slide in a clean, dry environment. Use gloves and avoid touching the slide surface.

1. Let the arrayed slides equilibrate to room temperature (20-30 minutes) before opening the moisture barrier bag.
2. Add blocking buffer to each subarray well.
3. Cover the wells with adhesive film to prevent evaporation and incubate slide on shaker at 80 rpm for 30 min. Longer incubation time is acceptable, but not necessary.

Make sure the orbital shaker is completely flat. If the slide is sloped in any direction during incubation it can cause variation in binding and detection.

Part 2 – Binding Assay

1. Unless the glycan binding protein sample of interest is bacteria or cells, centrifuge samples briefly to avoid adding irrelevant particles to the array.
2. Remove blocking buffer from each well by gently touching a pipette tip to the corner of the well, tipping the slide so that the sample pools to that corner, and pipetting off buffer. Avoid touching the array surface. Have the replacement buffer ready before removing the old buffer to ensure the array does not dry out.
3. Wash the wells three times by adding GAAB to each well and shaking the array at 80 rpm for 5 min. Remove the buffer and repeat.
4. Immediately apply the glycan binding protein sample of interest to each well. Avoid leaving air bubbles.

5. Seal the wells with adhesive film to prevent evaporation. If the sample is fluorescently labelled, cover with aluminum foil to keep it in the dark. Incubate on the shaker for 1 hour at 80 rpm. If the samples can easily aggregate, shake at higher speed to prevent protein aggregation. Longer incubation time may increase binding signal, especially for weakly binding samples.

Avoid allowing the slides to dry out at any point during the assay, especially during long incubation times. Make sure the adhesive film is sealed around each well.

If your glycan-binding protein samples are fluorescently labelled, go directly to Part 6 – Final Wash and Dry.

Part 3 – Wash

1. Remove buffer or sample from each well by gently touching a pipette tip to the corner of the well, tipping the slide so that the sample pools to that corner, and pipetting off buffer. Avoid touching the array surface.
2. Immediately add GAAB to each well. Incubate on the shaker for 5 minutes at 80 rpm. Completely remove the buffer by pipette and repeat this step twice more. Avoid allowing the slide to dry out by having your next wash or sample ready before you remove the buffer.

If your glycan-binding sample is biotinylated, go directly to Part 5 – Fluorescent Staining.

Part 4 – Binding of Biotinylated Antibody (Sandwich Assay Format)

1. Unless the secondary biotinylated antibody sample is bacteria or cells, centrifuge samples briefly to avoid adding irrelevant particles to the array.
2. After completely removing the third GAAB wash, immediately add the secondary biotinylated antibody to each well. Seal the wells with adhesive film and incubate on the shaker for 1 hour at 80 rpm. Shaking at a faster speed can prevent protein aggregation. Longer incubation time is acceptable, but not necessary.
3. After incubation repeat Part 3 – Wash.

Part 5 – Fluorescent Staining

1. Centrifuge fluorescent labeled streptavidin samples briefly to avoid adding irrelevant particles to the array.
2. After completely removing the third GAAB wash, immediately add the fluorescently labelled streptavidin sample. Seal the wells with adhesive film and shield the wells from light with aluminum foil. Incubate on the shaker at 80 rpm for 1 hour. Longer incubation time is acceptable, but not necessary.

Part 6 – Final Wash and Dry

1. Remove sample from each well by gently touching a pipette tip to the corner of the well, tipping the slide so that the liquid pools to that corner, and pipetting off. Avoid touching the array surface.
2. Briefly rinse each well with GAAB.
3. Completely remove the buffer by pipette. Avoid touching the array surface. Repeat steps 2 and 3.
4. Disassemble the cassette from the slide. For the provided cassette this can be done by holding the slide with one hand at the top and bottom edges and sliding out the cassette clips one by one with the other hand. If your provided cassette has metal clips they can be removed by rotating the clip outwards from the bottom of the slide. When the clips have been removed place the slide on the table and hold a small outer edge of the slide to the table as you gently peel the cassette off.

5. Immediately immerse the slide in a coplin jar or beaker full of GAAB. Do not touch the surface of the array or allow the array surface to touch the sides of the beaker or jar.
6. Place the jar or beaker on a shaker at 80 rpm for 10 minutes.
7. Decant the buffer from the jar or beaker while holding the slide in place (only touch the edge of the slide) and then add sterile de-ionized water to immerse the slide.
8. Place the jar or beaker on the shaker at 80 rpm for 2 minutes.
9. Decant the water from the jar or beaker. Repeat once more with fresh de-ionized water.
10. Allow the slide to dry completely in a clean, dust free environment before scanning.

Analysis

Scan the slide in a laser fluorescence scanner at the wavelength of emission for the fluorophore used. Adjust the laser power and PMT to obtain the highest possible signals without any being saturated (saturated positive control signal is okay). Analyze data with microarray analysis software. If there is specific binding the signal intensity should be higher than the background signal (area where there are no printed spots). Fluorescent signal due to specific binding to your sample of interest should be both dose-dependent with your sample dilution (unless the sample concentration range is too high and glycan binding is saturated) and should have positive binding signal after signal from control assays has been subtracted. Our standard method of comparing signal intensities is to quantify the median signal intensity data and subtract the background intensity. Subtracting signal from negative control spots as well as the same spots on a negative control assay (assay with only detection antibodies and fluorophore) will give more accurate specific binding data.

Interpretation of Control Signals:

Negative Control (Print Buffer): The negative control should produce a signal close to the intensity of the background. Since there is no binding involved with the negative control, any other signals around the negative control's intensity are also not binding.

Marker: The array marker should show fluorescence signal regardless of the assay. It is there primarily to aid with orientation of the array map during analysis.

Biotinylated Mannose (PC1): This positive control will bind directly to the fluorescent labelled streptavidin. If your glycan-binding protein sample is already fluorescently labelled, or in any case where the addition of fluorescently labelled streptavidin to the array was not performed (Part 5 – Fluorescent staining) this positive control will not be reactive.

IgG (PC2, PC3, PC4): IgG is an antibody found in blood that is a primary component of humoral immunity. If the glycan-binding or secondary antibody sample is an anti-IgG from human, rabbit, or mouse it should bind to the respective IgG control.

Typical Binding Assay Result from the 100 Glycan Array

Example 1: 100 glycan array on 8 subarray format. A subarray assayed with glycan-binding protein biotinylated ConA lectin (10 $\mu\text{g/ml}$), followed by Streptavidin-Cy3. Array was scanned with a microarray scanner at 532nm wavelength. All positive controls and the marker show binding as expected, as well as mannose-containing glycans 60, 65, 72, 73, 98, 99, and 100.

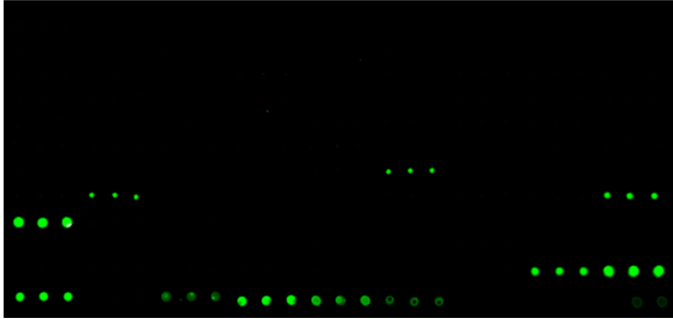

Example 2: 100 glycan array on 8 subarray format. A subarray assayed with glycan-binding protein biotinylated AAL lectin (1 $\mu\text{g/ml}$), followed by Streptavidin-Cy3. Array was scanned with a microarray scanner at 532nm wavelength. All positive controls and the marker show binding as expected, as well as fucose-containing glycans 5, 26, 35, 36, 38, 44, 45, 46, 53, 54, 56, 57, 66 and 81.

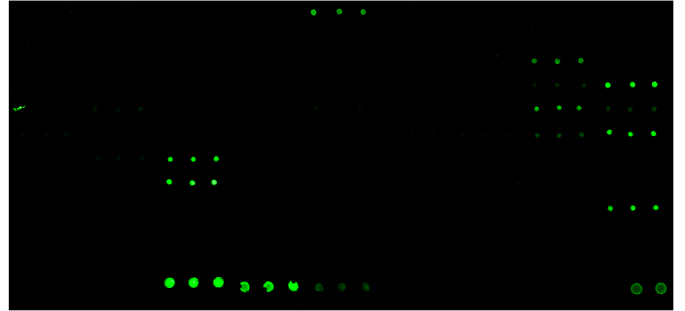

Troubleshooting

Condition	Possible Causes	Potential Solutions
High Background	<ul style="list-style-type: none"> • Concentration of glycan-binding protein samples is too high • Concentration of fluorescent samples is too high • Arrays are not thoroughly washed • Slide drying out during assay • Excessive particles in the samples due to sample aggregation, dust, etc. 	<ul style="list-style-type: none"> • Use a lower concentration range of samples. Consider a wider range if you are unsure where the detection limit is. • Apply longer times for washing steps and use a higher shaking rate • Make sure wash buffer and sample is completely removed before the next step • Make sure adhesive film fully seals the wells to avoid evaporation • Centrifuge the samples prior to assay to avoid adding irrelevant particles • If you think that the protein is aggregating during incubation, try shaking at a higher speed
Signal Variation	<ul style="list-style-type: none"> • Slide drying out during assay. • Binding samples are not equally distributed in the wells • Glycan-binding protein aggregation during incubation • Bubbles during incubation 	<ul style="list-style-type: none"> • Make sure wells are sealed to prevent evaporation during incubation. • Apply a larger volume of sample to each well to ensure equal distribution • Use a higher shaking rate during incubation • Make sure samples are homogeneous, mixed thoroughly, and do not leave bubbles on the array surface
Unexpected Binding	<ul style="list-style-type: none"> • Cross contamination between wells or other sources • Sample contamination 	<ul style="list-style-type: none"> • Make sure to use sterilized pipette tips and tubes used for sample application and preparation • Ensure cassette is pressed firmly to the slide so that there are no gaps to allow leaking between wells • Be careful not to cross contaminate samples when applying to the wells, even during wash steps